

F136 SERIES LUMINAIRE



HCI
Heritage Casting & Ironworks

1280 Fewster Drive
Mississauga ON L4W 1A4
sales@hcilighting.com
www.hcilighting.com
Fax (905) 238-9060

Toll-free (800) 267-3175 Tel. (905) 238-2648

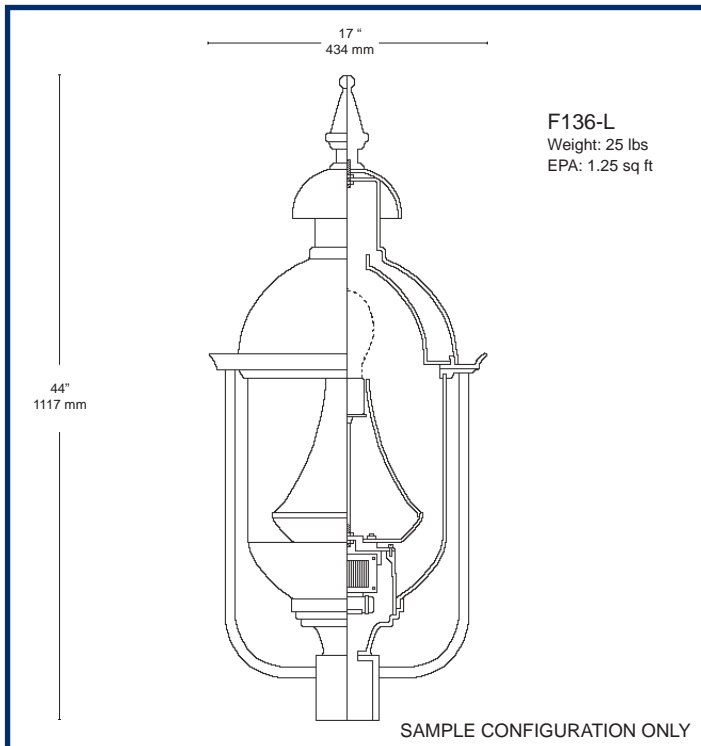

Description. The **F136** Series luminaire shall consist of an injection-molded UV stabilized tubular diffuser, a spun aluminum hood assembly, an internal optical system and a slip fitter (capital). The hinged hood shall rest on a cast aluminum ring welded to extruded aluminum struts. The diffuser shall be held in place with positive pressure applied by the hood assembly. As an option, lower third of the diffuser can be frosted. The fitter shall be made of cast aluminum and shall house the ballast assembly. The ballast shall feature quick disconnect plugs for easy ballast maintenance. The ballast shall be factory wired, tested and mounted on a keyholed cast aluminum plate together with a 4kV porcelain socket. Lamps are not included and shall be supplied by others. All electrical components shall be UL listed and labeled.

Installation. The fixture shall slip fit onto a 3" OD or 4" OD tenon (specify) and shall be secured to the pole with three sets of two s/s hex socket screws spaced 120° apart.

Finish. All applicable parts shall receive a standard electrostatically applied thermoset polyester powder coat smooth semi gloss finish with a four part corrosion inhibiting process.

To assemble a catalog number, list all codes sequentially.

1. SIZE

F136-L (17"W x 44"H)

2. DIFFUSER TYPE

- CAC** Clear Acrylic
CPC Clear Polycarbonate
CFA Clear/Frosted Acrylic
CFP Clear/Frosted Polycarbonate

3. LIGHT SOURCE (indicate wattage)

- 50 - 250 **MH** _____W
 Option: pulse start ballast
 35 - 250 **HPS** _____W
 55, 85 or 165 Philips® **QL** ¹ _____W
CFL Fluorescent _____W
INC Incandescent _____W

4. VOLTAGE (circle connected voltage)

- QT** (Quad Tap 120, 208, 240, 277)
TT (Tri Tap 120, 277, 347)
NOTE: Please circle connected voltage. If none is indicated, factory will pre-wire at 120V.
120V Reactor
480 Single

5. OPTICS

- BR3** glass refractor IES type III
BR5 glass refractor IES type V
SR3 horizontal cutoff segmented reflector IES type III
SR5 horizontal cutoff segmented reflector IES type V
LV louver reflector IES type V
OC dual optical cone IES type V
BL bare lamp

6. OPTIONS

- CHY** decorative glass chimney ²
FUS internal fusing
PCB luminaire integrated button type photocell
HSS house side shield

7. COLOR

- Black** RAL 9011
Green RAL 6005
Bronze RAL 8019
Grey RAL 7012
White RAL 9016
Custom

NOTES

- ¹ QL is available in 120V or 240V for 55W and 85W systems.
² Available with SR3 optics only.